

Quick-change adapters, positive drive *inch* sizes

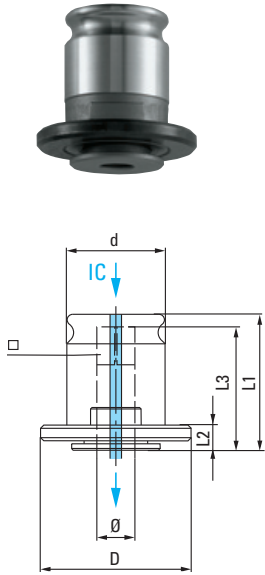

For quick change tap chucks TA, TIC, NC and SPD QC, with or without internal coolant system.

Features and Advantages

- equally appropriate for taps with internal coolant
- no pre-selective torque drive
- suitable for right and left hand tapping

Model	Adapter Size	Dimensions			
		d mm	L1 mm	D mm	L2 mm
P0	0	13	26.5	22	7
P1	1	19	28.5	30	7
P2	2	31	46.5	48	11
P3	3	48	68.5	70	14
P4	4	60	105.0	92	42

Product range – Adapters

Tap	Shank Ø inch	Square inch	Order code P0	Order code P1	Order code P2	Order code P3	Order code P4
#0 - #6	.141	.110	1001	1006			
#8	.168	.131	1002	1007			
#10	.194	.152	1003	1008	1016		
#12	.220	.165	1004	1009			
1/4"	.255	.191	1005	1010	1017		
5/16"	.318	.238		1012	1018		
3/8"	.381	.286		1013	1019		
7/16"	.323	.242		1014	1020		
1/2"	.367	.275		1015	1021		
9/16"	.429	.322		10155	1022		
1/8" Pipe	.313	.234		10166	10266		
1/8" Pipe	.438	.328		10177	10277		
5/8"	.480	.360			1023		
11/16"	.542	.406			1024		
3/4"	.590	.442			1025		10392
13/16"	.652	.489			1026	1031	
7/8"	.697	.523			1027	1032	
1/4" Pipe	.562	.421			10288		
3/8" Pipe	.700	.531			10299	10386	
1/2" Pipe	.687	.515			10300	10387	
15/16"	.760	.570				1033	
1"	.800	.600				1034	10391
1 1/8"	.896	.672				1035	10393
1 1/4"	1.021	.766				1036	1039
1 3/8"	1.108	.831				1037	1040
3/4" Pipe	.906	.679				10388	10440
1" Pipe	1.125	.843				10389	10442
1 1/2"	1.233	.925					1041
1 5/8"	1.305	.979					1042
1 3/4"	1.430	1.072					1043
1 7/8"	1.519	1.139					10435
1 1/4" Pipe	1.312	.984					10444
1 1/2" Pipe	1.500	1.125					10455
2"	1.644	1.233					1044

Quick-change adapters, positive drive metric sizes

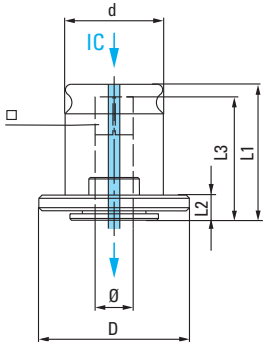

For quick change tap chucks TA, TIC, NC and SPD QC with or without internal coolant system.

Features and Advantages

- equally appropriate for taps with internal coolant
- no pre-selective torque drive
- suitable for right and left hand tapping

Model	Adapter Size	Dimensions			
		d mm	L1 mm	D mm	L2 mm
P0	0	13	26.5	22	7
P1	1	19	28.5	30	7
P2	2	31	46.5	48	11
P3	3	48	68.5	70	14
P4	4	60	105.0	92	42

Quick change adapters, positive drive metric sizes

Tap	Shank Ømm	Square mm	Order code P0	Order code P1	Order code P2	Order code P3	Order code P4
M2, M2.5, M4	2.8	2.1	P0-028021				
M3, M5	3.5	2.7	P0-035027	P1-035027			
M3.5	4	3	P0-040030	P1-040030			
M4	4.5	3.4	P0-045034	P1-045034			
M4, M4.5	5	4	P0-050040	P1-050040			
M4.5, M5, M6, M8	6	4.9	P0-060049	P1-060049	P2-060049		
M8	8	6.2	P0-080062*	P1-080062	P2-080062		
M7, M9, M10	7	5.5	P0-070055*	P1-070055	P2-070055		
M12	9	7		P1-090070	P2-090070		
M10	10	8		P1-100080	P2-100080		
M14	11	9		P1-110090		P3-110090	
M16	12	9			P2-120090	P3-120090	
M18	14	11			P2-140110	P3-140110	
M20	16	12			P2-160120	P3-160120	
M22, M24, M25, M26	18	14.5			P2-180145	P3-180145	P4-180145
M27, M28	20	16				P3-200160	P4-200160
M30, M32	22	18				P3-220180	P4-220180
M33	25	20				P3-250200	P4-250200
M34, M35, M36, M38	28	22				P3-280220	P4-280220
M39, M40, M42	32	24					P4-320240
M45, M48, M50	36	29					P4-360290

Note: Version with (*) only suitable for light processing

Note: other sizes available on request.

Quick-change adapters, with pre-selective torque drive *inch sizes*

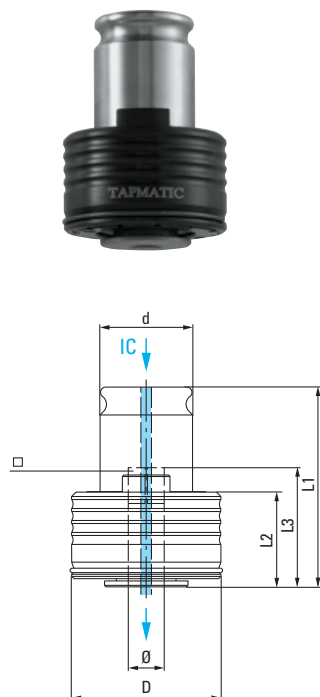

For quick change tap chucks TA, TIC, NC and SPD QC, with or without internal coolant system. A pre-selective torque drive protects the tap from breakage.

Features and Advantages

- equally appropriate for taps with internal coolant
- with pre-selective torque drive
- suitable for right and left hand tapping

Model	Adapter Size	Dimensions			
		d mm	L1 mm	D mm	L2 mm
TC0	0	13	40.5	23	21
TC1	1	19	46.5	32	25
TC2	2	31	69	50	34
TC3	3	48	100.5	72	45
TC4	4	60	131	95	68

Product range – Adapters with torque control

Tap	Shank Ø inch	Square inch	Order code TC0	Order code TC1	Order code TC2	Order code TC3	Order code TC 4
#0 - #6	.141	.110	1046	1051			
#8	.168	.131	1047	1052			
#10	.194	.152	1048	1053			
#12	.220	.165	1049	1054			
1/4"	.255	.191	1050	1055	10614		
5/16"	.318	.238		1056	1062		
3/8"	.381	.286		1057	1063		
7/16"	.323	.242		1058	1064		
1/2"	.367	.275		1059	1065		
9/16"	.429	.322		10595	1066		
1/8" Pipe	.313	.234		10600			
1/8" Pipe	.438	.328		10611			
5/8"	.480	.360			1067		
11/16"	.542	.406			1068		
3/4"	.590	.442			1069	1074	
13/16"	.652	.489			1070	1075	
7/8"	.697	.523			1071	1076	
1/4" Pipe	.562	.421			10722		
3/8" Pipe	.700	.531			10733	1082	
1/2" Pipe	.687	.515			10744	10821	
15/16"	.760	.570				1077	
1"	.800	.600			10711	1078	10835
1 1/8"	.896	.672				1079	10836
1 1/4"	1.021	.766				1080	10837
1 3/8"	1.108	.831				1081	1084
3/4" Pipe	.906	.679				10822	10880
1" Pipe	1.125	.843				10833	10882
1 1/2"	1.233	.925					1085
1 5/8"	1.305	.979					1086
1 3/4"	1.430	1.072					1087
1 7/8"	1.519	1.139					10875
1 1/4" Pipe	1.312	.984					10899
1 1/2" Pipe	1.500	1.125					10900

Quick-change adapters, with pre-selective torque drive *metric sizes*

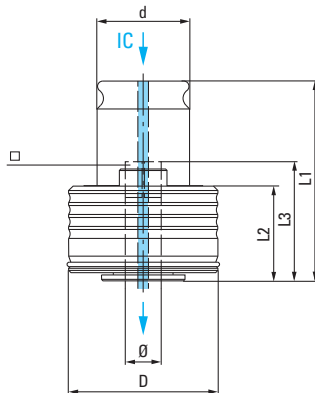

For quick change tap chucks TA, TIC, NC and SPD QC, with or without internal coolant system. A pre-selective torque drive protects the tap from breakage.

Features and Advantages

- equally appropriate for taps with internal coolant
- with pre-selective torque drive
- suitable for right and left hand tapping

Model	Adapter Size	Dimensions			
		d mm	L1 mm	D mm	L2 mm
TC0	0	13	40.5	23	21
TC1	1	19	46.5	32	25
TC2	2	31	69	50	34
TC3	3	48	100.5	72	45
TC4	4	60	131	95	68

Product range – Adapters with torque control

Tap	Shank Ø mm	Square mm	Order code TC0	Order code TC1	Order code TC2	Order code TC3	Order code TC4
M2, M2.5, M4	2.8	2.1	TC0-028021				
M3, M5	3.5	2.7	TC0-035027	TC1-035027			
M3.5	4	3	TC0-040030	TC1-040030			
M4	4.5	3.4	TC0-045034	TC1-045034			
M4, M4.5	5	4	TC0-050040	TC1-050040			
M4.5, M5, M6, M8	6	4.9	TC0-060049	TC1-060049	TC2-060049		
M8	8	6.2	TC0-080062*	TC1-080062	TC2-080062		
M7, M9, M10	7	5.5	TC0-070055*	TC1-070055	TC2-070055		
M12	9	7		TC1-090070	TC2-090070		
M10	10	8		TC1-100080	TC2-100080		
M14	11	9		TC1-110090	TC2-110090	TC3-110090	
M16	12	9			TC2-120090	TC3-120090	
M18	14	11			TC2-140110	TC3-140110	
M20	16	12			TC2-160120	TC3-160120	
M22, M24, M25, M26	18	14.5			TC2-180145	TC3-180145	TC4-180145
M27, M28	20	16				TC3-200160	TC4-200160
M30, M32	22	18				TC3-220180	TC4-220180
M33	25	20				TC3-250200	TC4-250200
M34, M35, M36, M38	28	22				TC3-280220	TC4-280220
M39, M40, M42	32	24					TC4-320240
M45, M48, M50	36	29					TC4-360290

Note: Version with (*) only suitable for light processing

Quick-change collet chuck adapters for rubber flex collets (RF)

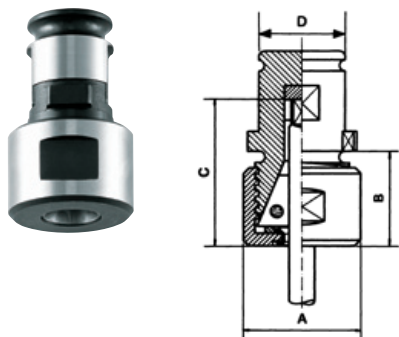

Tap holders with various or adjustable back jaws for quick change tap chucks TA and NC. Only 2 multi-range collets (RF) per type necessary to cover capacity.

Delivery

Accessories include wrench and necessary square drives for the specified capacity. Please note that rubber flex collets are also included

Model	Order code	Tap size	Collets Rubber Flex Included	Dimensions			
				A mm	B mm	C mm	D mm
TF0	29350	M1.4–M7	21600 21700	18.6	18.6	21.0	13
TF1	29351	M3–M12	22100 22200	27.4	18.6	27.0	19
TF2	29352	M5–M18	24100 24500	37.2	24.6	38.1	31
TF3	29353	M10–M30	26100 26200	54.0	31.8	50.5	48

Rubber Flex multi-range collets

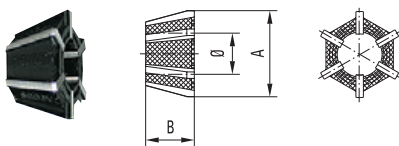

Rubber Flex collets for TAPMATIC tapping attachments and chucks.

Model capacity	Order code	Capacity mm	Type	Model capacity	Order code	Capacity mm	Type
M1.4 - M7 #0 - 1/4"	21500	1.0–2.5	Extra	M5 - M18 #10 - 3/4"	24000	7.0–13.0	Extra
	21600	2.5–4.5	Standard		24100	4.5–10.0	Standard
	21700	4.5–6.5	Standard		24300	2.8–7.0	Extra
M3 - M12 #6 - 1/2"	22000	4.5–8.0	Extra	24500	10.0–15.0	Standard	
	22100	3.5–6.5	Standard	M10 - M30 1/2" - 1 1/8"	26100	10.0–16.0	Standard
	22200	6.5–10.0	Standard		26200	16.0–23.0	Standard
	22300	2.0–4.5	Extra				

XB collets



For TAPMATIC miniature tapping attachment model 100XB.

Model	Order code	Capacity mm	Type	Model	Order code	Capacity mm	Type
117XB1	20100	0.9–1.0	DIN 376	117XB5	20500	2.0–2.2	DIN 376
117XB2	20200	1.1–1.25	ISO	117XB6	20600	2.3–2.5	DIN 371
117XB3	20300	1.4–1.55		117XB7	20700	2.8–3.0	ISO
117XB4	20400	1.6–1.8		117XB8	20800	3.3–3.6	

All dimensions are shown in mm. 25.4mm = 1"