

High speed tapping attachments with modular straight shank, without internal coolant system

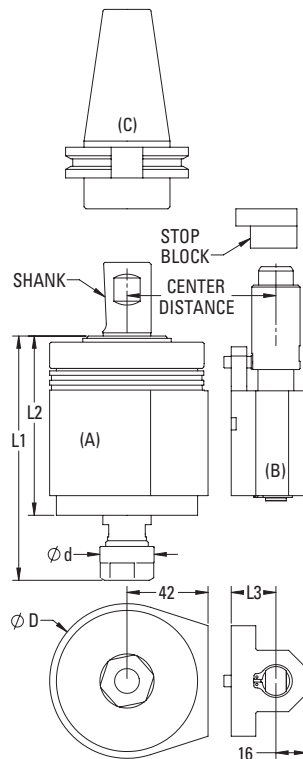

Features and Advantages

- high speed self-reversing tapping for fastest cycle time
- rugged design for years of production, with little maintenance
- simple installation and programming
- large capacity

How to Order

Please select the Tapping attachment (A), stop arm (B) and CAT, SK, or BT shank (C), to fit your machine. Accessories like steel collets, sealing gaskets and stop blocks are not included. Please order these separately.

Tapmatic can provide a complete tool ready to fit your machine. Please simply provide the information shown on installation page 55, fill in the form on the back cover or contact us directly.

(A) Tapping Attachment RDT Cylindrical Shank



Model	Order code	Capacity (steel)	Shank	Collets	Max. RPM	Weight kg	D	d	L1	L2
RDT15	3915258HD	M1-M3	25 mm	ER8	5000	1.7	57	12	97	79
	391518HD	#0-#6	1"							
RDT25	39252511	M2-M6	25 mm	ER11	4000	1.7	57	19	106	79
	3925111	#4-1/4"	1"							
RDT50	39502516	M4.5-M12	25 mm	ER16	2000	3.7	80	28	126	93
	3950116	#10-1/2"	1"							

Notes: When using Roll Form Taps the tool's capacity must be reduced 25%.
To hold larger taps with RDT50 ER16, use standard collet 20953 and separate square drives packaged with tool.
All dimensions are shown in mm. 25.4mm = 1"

(B) Stop Arm Assembly



Center Distance (42+L3)	Order code RDT15	Order code RDT50	L3
55	3925551	3950551	13
65	3925651	3950651	23
80	3925801	3950801	38



Stop Block
Page 55

