

# Safety And Operation Instructions

## RSR50 VMC Right Angle Self-Reversing Tapping Units



**WARNING** To Avoid Serious Injury And Ensure Best Results For Your Tapping Operation, Please Read Carefully *All* operator and safety instructions provided for this tapping attachment as well as all other safety instructions that are applicable, especially those for your machine tool.



**1. Proper Clothing:** The rotating spindle of a machine tool can snag loose fitting clothing, jewelry or long hair. **Never** wear jewelry, long sleeves, neckties, gloves or anything else that could become caught when operating a machine tool. Long hair **must** be restrained or netted to prevent it from becoming entangled in rotating spindle.



**2. Proper Eye Protection:** Always wear safety glasses with side shields to protect your eyes from flying particles.

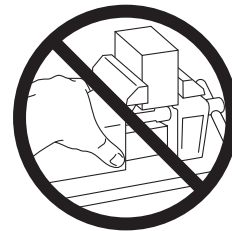

**3. Proper Work Piece Fixturing:** **Never** hold the work piece or the vise it is held in, by hand. The work piece **must** be clamped firmly to the table of the machine so that it cannot move, rotate or lift.



### 4. On Machining Centers:

Please remember that the stop block installation must be stronger than the largest tap. **Automatic tool changes should only be made on enclosed machines.**

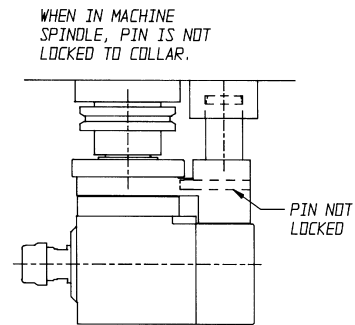
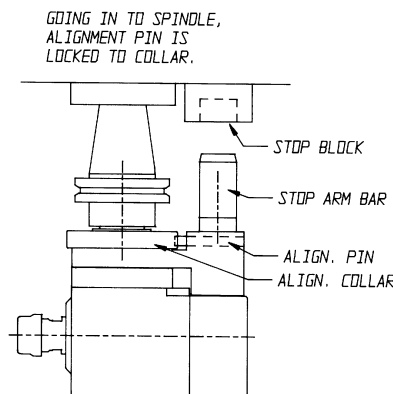

**5. The tapping attachment housing, drive spindle and tap itself can become hot to the touch after operation. Use caution when removing the attachment from the machine or handling.**



**6. Always Be Aware Of The Potential Hazards Of A Machining Operation:** Sometimes working with your machine can seem routine. You may find that you are no longer concentrating on the operation. A feeling of false security can lead to serious injury. **Always** be alert to the dangers of the machines with which you work. **Always** keep hands, body parts, clothing, jewelry and hair out of the areas of operation, when the machine spindle is rotating. Areas of operation include the immediate point of machining and all transmission components including the tapping attachment. **Never** bring your hand, other body parts or anything attached to your body into any of these areas until the machine spindle is completely stopped.



**7. Be aware of any other applicable safety instructions / requirements.**

### Check List For Good Tapping



- 1. **Never** use this unit before reading all safety instructions for this attachment as well as the machine it is to be used on.
- 2. Is tap sharp and of correct design for current job?
- 3. Is tap in proper alignment with drilled hole?
- 4. Is machine speed correct?
- 5. Is machine feed correct?
- 6. Is machine stop set properly so tap releases in neutral rather than bottoming in work piece or fixture?
- 7. Is drilled hole the correct size?
- 8. Is clearance between the drilled hole and tap sufficient at start position to allow the tap to clear the hole upon retraction?
- 9. Is the stop arm of the tapping attachment held rigidly against rotation. Stop Arm installation must be stronger than largest tap.
- 10. Is the proper cutting fluid or coolant being used for lubricating the tap?
- 11. If a bottom hole is being tapped is there sufficient chip clearance?
- 12. Is the correct Tapmatic model for the specific job requirement being used? (Capacity should be reduced 25% for roll form taps.)

References for this Safety Information include but are not limited to:

American National Standards Institute  
ANSI B11.8-1983 (Adopted May 31, 1983  
by Department of Defense)

Coastal Video Communications Corporation  
Machine Guarding Copy Right 1994

Society Of Manufacturing Engineers  
Tool and Manufacturing Engineers Handbook  
Volume 1 Machining  
(Library of Congress Catalog No. 82-060312)

# Programming

## RSR50 VMC Right Angle Self-Reversing Tapping Units

Thank you for purchasing a Tapmatic RSR VMC model. Please read this instruction sheet carefully before using the attachment.

### RSR PROGRAMMING SUGGESTION

Right hand machine rotations result in right hand tapping. Do not run in left hand direction. Damage to tool could occur.

- 1.) Write sub-routine (Feed in at 64% of machine RPM feed rate, no dwell. Feed out at 68%.)
- 2.) Rapid approach to clearance plane (.500 or 12mm) away from hole to be tapped.
- 3.) Call up sub-routine described above, making sure to feed all the way back to clearance plane.
- 4.) For blind holes or controlled thread depth, machine feed to desired thread depth minus an allowance for variation in machine feed and reaction time.

Note: The RSR attachment reduces the machine spindle speed input by 33% for tapping.

The programming calculations we have given for the feed rate are based on the machine spindle input speed. Always run at the cutting speeds recommended by the tap manufacturer but not to exceed the maximum speed for the tapping attachment. Maximum machine input speed 3000 RPM results in maximum tapping speed 2000 RPM.

**Through Hole Tapping:** Simply feed to desired depth and retract.

**Controlled Thread Depth Tapping:** Follow the same steps as outlined above. However, the machine program depth must be slightly shallower than the actual depth of thread desired.

When using the RSR VMC, subtract .150 from the depth of thread required and use this value in your program. Please note that the actual depth will be slightly shallower than the required depth. Check thread depth on the first hole tapped and make any necessary adjustments to your program.

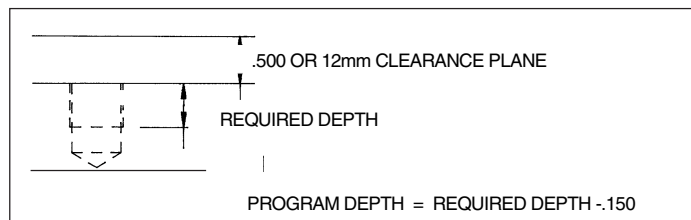

The thread depth during a production run will stay accurate within a small fraction of a revolution.

**Steel Collet Spindle:** Select the proper steel collet for the tap, (Steel collets must be ordered separately.) Insert the collet into the nut being sure to fix pawl of collet nut with the seat of the collet for assembly and then mount into the spindle.

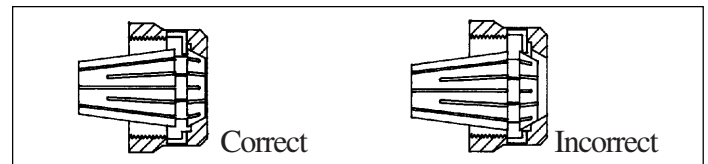

Next, insert the tap and tighten collet nut firmly with wrenches provided. There are square sockets inside the drive spindle for the largest tap size. Please use collets with internal square drive whenever possible.

**VERY IMPORTANT NOTICE**

**Regarding Ramp or Exact Stop:** Please note that the G code for "Exact Stop" or "Ramp" should not be used with a Tapmatic self-reversing tapping attachment. Please be sure that these are not in effect when tapping because they will cause the tapping cycle time to be significantly slower and thread depth repeatability to be less accurate.

**Fadal Machines:** Use G8 to cancel the Ramp for tapping. G9 will turn the Ramp on again if desired for other operations.

**Machines With Fanuc Controls and Haas Machines:** Use G64 while tapping to eliminate the Exact Stop. G61 will make Exact Stop modal again for other operations if desired.

**REDUCING CYCLE TIME:** If you are looking for ways to reduce cycle time further, please consult our Tapmatic Sales Engineers. They can give you specific recommendations for your application. CALL (800) 854-6019 Toll FREE.

### Feed Rate Calculations

#### Inch Taps:

- Feed Rate of Tap** = RPM divided by Pitch  
**Example:** 1/2-20 at Machine Speed of 1000 RPM  
 (Tapping Speed 666 RPM)
- Feed Rate In** = 1000 RPM divided by 20 rev/inch x .64  
**Feed Rate In** = 32 in/min  
**Feed Rate Out** = 1000 RPM divided by 20 rev/inch x .68  
**Feed Rate Out** = 34 in/min.

#### Metric Taps:

- Feed Rate Of Tap** = RPM x Pitch  
**Example:** M12 x 1.75 at Machine Speed of 1000 RPM  
 (Tapping Speed 666 RPM)
- Feed Rate In** = 1000 RPM x 1.75 mm/rev x .64  
**Feed Rate In** = 1120 mm/min.  
**Feed Rate Out** = 1000 RPM x 1.75 mm/rev. x .68  
**Feed Rate Out** = 1190 mm/min.

### Feed Rate Note: For High Speed Tapping

All CNC machines vary in their ability to advance or retract rapidly for the short distances required in small hole tapping at high rpms. While the control may be set exactly for the required feed rate, the mass of the machine spindle or head will not reach that feed rate instantaneously. In fact, it may not reach it all before the machine stops advancing.

An accurate feed rate is essential if the machine is to keep up with the tap, which is definitely advancing at the proper feed rate, since it is influenced solely by rotation (rpms).

If you note the spindle of the RSR VMC chattering during entry or retraction, this merely indicates that the machine feed rate is not keeping up with the tap feed rate. The Tapping Attachment spindle is rapidly engaging and disengaging from drive.

To correct this, either reduce the rpms until the chattering stops and the tap enters and retracts smoothly or increase the feed rate until the same occurs. A third alternative is to increase the clearance plane above the work piece. This will give the attachment time to get up to the proper feed rate before entering the hole. The problem described above is common when tapping with small taps.

# Installation

## RSR50 VMC Right Angle Self-Reversing Tapping Units

In order for the RSR50 VMC model to self-reverse, a stop arm is used to prevent the housing from rotating. The RSR50 VMC is simple to use when loading and unloading by hand. If using the tool this way, remember to follow all safety rules for tapping attachment and machine. In particular see safety rule ▲ 6 on page 1. Also be sure stop arm bar is cut to proper length as shown below. The RSR50 may also be used with an automatic tool change. It will depend on the clearances on your machine. If you wish to use an automatic tool change follow instructions carefully and be sure to call Tapmatic if you have any questions. To allow the tool to travel through an automatic tool change and the stop arm to find the stop location next to your machine spindle, an Alignment Collar locks the stop arm in a specific orientation. This alignment collar can be adjusted so that its slot is in any position in relationship to the NC shank. When the tool is out of the machine spindle, the Alignment Pin is engaged in the slot in the alignment collar. This pin then keeps the stop arm locked in its orientation position. When the tapping attachment is placed in the machine spindle by the tool changer, the stop location next to the spindle engages the stop arm bar preventing it from turning and at the same time pushes it down against a spring so that the pin is unlocked from the alignment collar. This is the position for operation. When the tapping operation is completed the machine spindle orients to the tool change position bringing the slot in the alignment collar back into position to accept the alignment pin as the tool is removed from the machine spindle by the tool changer. The RSR50 VMC comes standard with either a 65mm or 80mm center distance from machine spindle center to stop arm bar center. If you require a special center distance please consult a Tapmatic sales engineer.

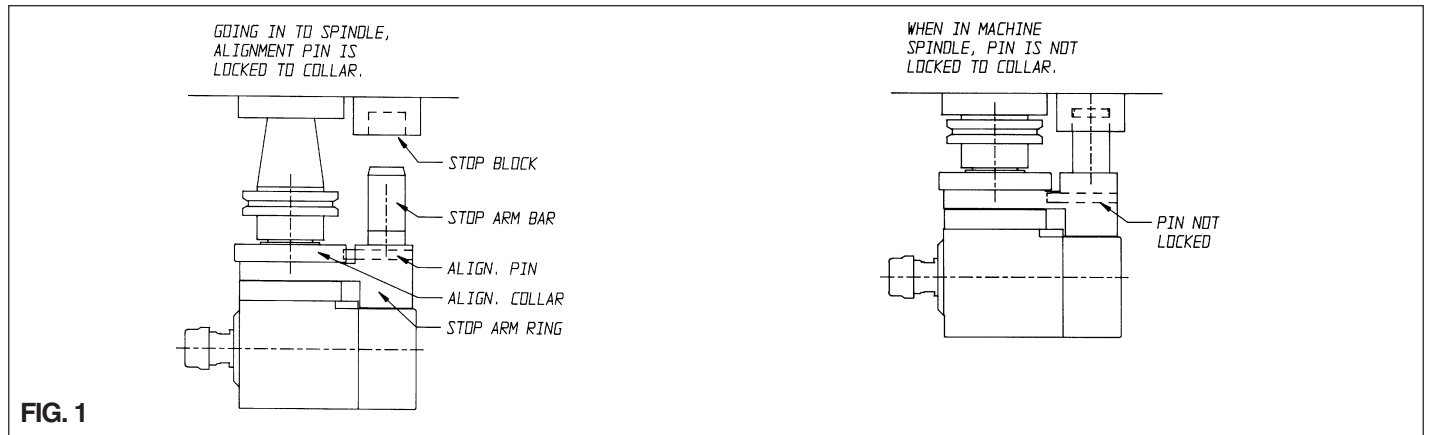

**⚠ The Following Steps Involve Loading and Unloading By Hand. Do Not Attempt An Automatic Tool Change Until All Steps Are Completed And Clearance Has Been Confirmed.**

**⚠ Never attempt any installation without first reading all safety instructions for this tool and your machine.**

**Step 1. Machining the Stop Arm Bar:** If you wish to make use of an existing stop block on your machine, measure the dimensions shown in FIG 2 (B,E, and G). The Stop Arm Bar should be removed from the tapping attachment, but the spring loaded plunger should still be in place when measuring. The stop arm bar length is calculated from the formula  $L = G + E + .37$  where  $.37$  or  $9.4\text{mm}$  is the distance that the stop arm needs to be compressed in order to release the alignment pin from alignment collar. (Please see FIG. 3) The diameter of the stop arm bar should be a close fit with the inside diameter of the hole in the stop block. To calculate stop arm bar diameter use the formula  $D = B - .005$ , where  $.005$  or  $.13\text{mm}$  is the clearance desired. Please be sure to turn a generous 15 degree chamfer to help guide the stop arm bar into the hole.

If possible, a taper to taper contact between stop arm bar and stop block is highly recommended. This eliminates side to side play and ensures that the stop arm bar will engage the stop block smoothly. FIG 4 below shows the Tapmatic Taper Stop Block and recommended dimensions for machining the taper. The length can be calculated similarly to the formula shown in FIG 3. Please note that this solution may not work on horizontal machines. Please consult a Tapmatic sales engineer.

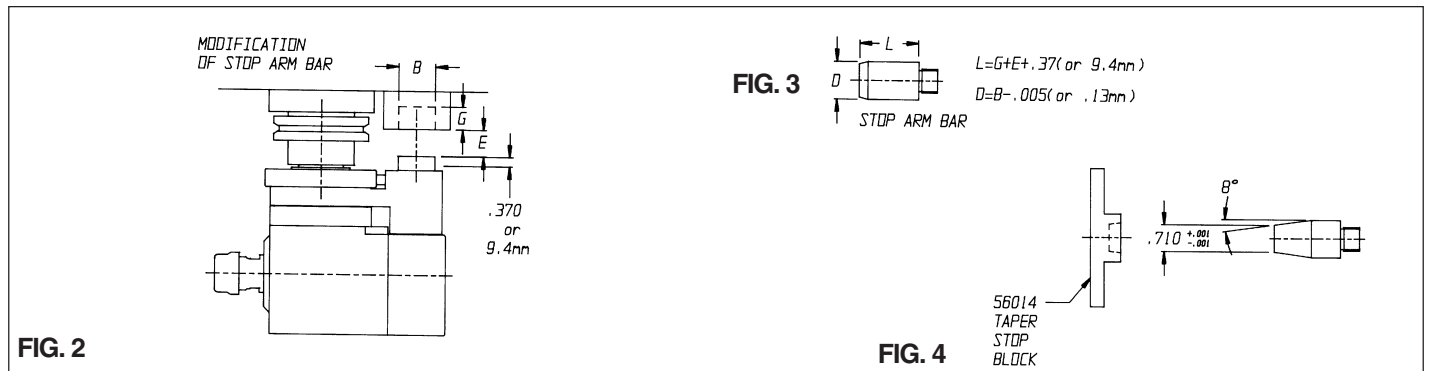

# Installation

## RSR50 VMC Right Angle Self-Reversing Tapping Units

**Step 2. Radial Positioning:** The RSR 50 VMC stop arm can be bolted to the top of the housing in four different positions at 90 degree increments. Within each of these positions there is also adjustability so that you can set the position independently of the stop block location. Please note that when setting position or when choosing a stop block location, if you are installing your own stop block, it is necessary to check carefully for any possible interference with the tool changer or in the tool storage area. **Always** confirm clearance before trying an automatic tool change. In some instances it may be necessary to load the RSR50 VMC by hand. To adjust the radial position, remove the alignment collar from the tapping attachment be sure the machine spindle is locked in the tool change orientation position, and then reinstall the attachment into the machine spindle as shown in FIG. 5. The clamping bolts should be in the position desired and tightened loosely so that the stop arm ring can still be turned but can not be tilted from pressure of the stop arm. Make the position adjustment by turning the housing of the RSR50 VMC. You may be able to use an indicator on your table to either sweep across the front of the housing or along a gage pin placed in the ER16 collet chuck to be sure your tap is oriented properly with the work piece. This is possible when orientation is along the X or Y axis. When aligned properly, tighten setting screw shown in FIG. 5. Then remove the RSR50 VMC from the machine and firmly tighten all four clamping bolts. The setting screw can now be removed. In addition to the bolt locations, there are also three other tapped holes. One of these holes should be used as a pin location. Choose a hole over solid material and drill a 5 mm hole through this location into the top of the housing approximately .250 or 6mm deep. If none of the holes are over completely solid material, one of them may be directly over one of the M5 tap hole locations. You can drill .250 or 6mm deep into this location, removing the threads with a 5mm drill, and use this location for your pin. After drilling install the threaded pin provided with your wrench kit. After this last step the alignment collar and shank can be reassembled with the RSR50 VMC.

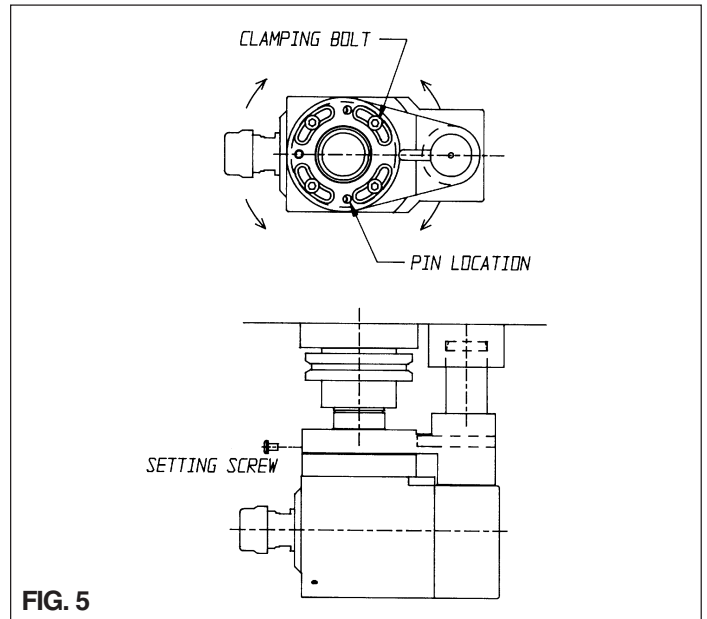

FIG. 5

**Step 3. Adjustment of Alignment Collar:** With tapping attachment in machine spindle and stop arm bar engaged in stop block, orient machine spindle to the tool change position. Bring slot in alignment collar in line with alignment pin and tighten alignment collar's cap screw. With attachment adjusted and after checking for any possible clearance problems with tool changer or in storage area make several automatic tool changes.

Note: If you would like Tapmatic to supply tools already modified to fit onto your machine, please contact our factory. Call (800) 854-6019. We will require some information about your machine to prepare the tool.

# Installation And Accessories

## RSR50 VMC Right Angle Self-Reversing Tapping Units

Steel Collet With Square Drive For RSR 50 VMC			
<i>Please select Square Drive Collets whenever possible.</i>			
Steel Collets With Square Drive	Catalog No.	Collet Range	
		Tap Size	Shank Size
#16 Series For RSR50 VMC	21006	#10	.194
	21008	#12	.220
	21010	1/4"	.255
	21012	5/16"	.318
	21014	7/16"	.323

Steel Collet Without Square Drive For RSR50 VMC			
<i>Please select Square Drive Collets whenever possible.</i>			
Steel Collet Series w/o Internal Squares	Catalog No.	Collet Range	
		Tap Size	Shank Size
#16 Series For RSR50 VMC	20940	#6	.118-.157
	20943	#8, #10	.157-.197
	20945	#12	.197-.236
	20946	1/4"	.236-.276
	20949		.276-.315
	20950	5/16", 7/16"	.315-.354
	20953	3/8"-1/2"	.354-.394

Wrench Kits			
	Qty.	Catalog #	Description
RSR50 VMC Model	1	28100	Wrench
	1	28075	3/4" Wrench
	1	29080	#10 Hook
	1	29090	Spring Puller
	1	27224	4mm Hex Key
	1	27221	2.5mm Hex Key
	1	71162	Setting Screw
	1	70426	Stop Arm Lock Pin

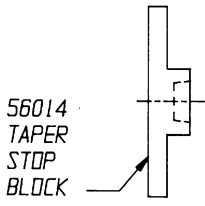
Tapmatic Taper Stop Block	
Catalog No.	
	56014

# Maintenance And Repair

## RSR50 VMC Right Angle Self-Reversing Tapping Units

### MAINTENANCE

**Lubrication:** We recommend lubrication every 100,000 cycles. To lubricate remove grease hole plug and add grease from the tubes provided. Use two tubes. For additional tubes, order part number 29000 for a box of 12. We recommend Prolong EP2 Grease and SPL100 Spray. The units come from the factory already lubricated for operation. You may also lubricate the gears during the renewable drive inspection procedure. Please use caution not to over grease the tapping attachment. Too much grease causes heat and may clog air vent system or prevent drive spindle from returning properly.

**If Coolant Enters Unit:** If coolant somehow goes past the housing seals and enters the unit, you can follow the disassembly procedure explained above, clean the parts and re-grease. We recommend following a procedure like this also if you plan to store the unit for a long period of time.

**Repair Service is available at...**

**Attention:**

**Repair Department  
Tapmatic Corporation  
802 Clearwater Loop  
Post Falls, ID 83854**

**To Expedite Repair:** Return tool direct to Tapmatic Corporation, by United Parcel Service and enclose the following statement with your purchase order: "**Authorization given to repair and return tool without notification if total repair cost does not exceed 40% of the cost of a new tool.**" Tapmatic will repair the tool and call to request your credit card # for invoicing.

**Important:** Be sure to return the tool complete with the tap chuck nut, back jaw and if the tool is a reversing unit, include stop arm. Otherwise, we will add these missing parts to every non-warranty repair.

**Cost Notification:** Tapmatic will FAX a cost notification to you, soliciting your approval before repairs are completed.

If it is determined that a tapping attachment cannot be repaired, at the customer's request, Tapmatic will return the disassembled parts. We are not able to reassemble tapping attachments using damaged or worn out parts.

**Optional Return Procedure:** Tools may also be returned for repair through your local Tapmatic Distributor. They will ship the tool to us and include instructions for the repair and return. You may already have an open account with them which facilitates the handling of invoicing.

**Priority Service:** Tapmatic services tapping attachments returned for repair in the order in which they are received. All tools will be evaluated and repaired within three weeks from the date they arrive subject to receiving the customer's approval to proceed with the repair.

Priority is given to the tools shipped to us by overnight or second day.

If a repair is sent to us by UPS ground or similar service it can also be given priority. Just call and let us know you need priority service and advise if you would like the tool returned to you by overnight or second day. In the interest of fairness, to all our customers, we ask that you approve return shipment by overnight or second day before we agree to upgrade your repair order to priority service. Typical turnaround, not including shipping time, for priority repairs is 3 days subject to receiving the customer's approval to proceed with the repair.

If we can answer any questions, please call our toll free number: 800 395-8231.

# **TAPMATIC**

*The Tapping Specialists*

**TAPMATIC CORPORATION- ISO 9001 CERTIFIED**  
802 CLEARWATER LOOP, POST FALLS, IDAHO 83854  
Phone: (208) 773-8048, (800) 854-6019, FAX: (208) 773-3021



**Distributed By:**

Form#: 0318/RSR50VMC/