

# Safety and Operation for 90X II Self Reversing Tapping Attachments

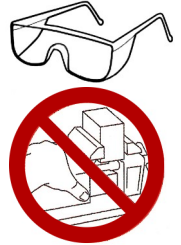

**Warning:** To avoid serious injury and ensure best results for your tapping operation, please read carefully *all* operator and safety instructions provided for this tapping unit as well as all other safety instructions that are applicable, especially those for your machine.

- Proper Clothing:** The rotating spindle of a machine tool can snag loose fitting clothing, jewelry or long hair. **Never** wear jewelry, long sleeves, neckties, gloves or anything else that could become caught when operating a machine tool. Long hair **must** be restrained or netted to prevent it from becoming entangled in rotating spindle.
- Proper Eye Protection:** **Always** wear safety glasses with side shields to protect your eyes from flying particles.
- Proper Work Piece Fixturing:** **Never** hold the work piece or the vise it is held in by hand. The workpiece **must** be clamped firmly to the table of the machine so that it cannot move, rotate or lift.
- Proper Stop Arm/Torque Bar Installation for Self-Reversing Attachments On Conventional Machines.**



**Always mount a torque bar to hold the tapping attachments stop arm from rotating.** The torque bar **must** be mounted securely to the table or quill of your machine. The torque bar installation **must be stronger** than the largest tap in the capacity range of your tapping attachment. The surface of the torque bar **must be smooth** to allow the stop arm to slide freely when feeding in and out of the hole. Order Tapmatic Torque Bars shown.

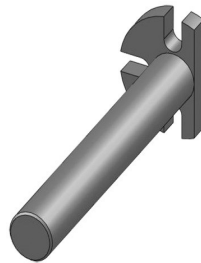

Torque Bar Assembly	Order No.	Max Tap Size
Heavy Duty Table Mount	29096	1 3/4" or M42

**Never extend the length of the standard stop arm supplied with your tapping attachment.** A lengthened stop arm could break free hitting the operator and causing serious injury.



**Never hold the stop arm by hand.** On reversal, full power of the machine is transmitted through the stop arm and the operator could be seriously injured.



**5. Do not exceed the maximum speed for the tapping head:** Speed is a critical factor in tapping. Please always refer to recommended tapping speed chart. Tapmatic torque control reversing tapping attachments employ a planetary gear for increased speed in reverse. The revolutions per minute when reversing out of the hole will be 1.75 times faster than the machine spindle speed. It is strongly recommended that you consider the **Average Tapping Speed** rather than machine speed when calculating cycle time. For example if machine speed is 600 RPM, reverse speed is 1050 RPM making your Average Tapping Speed 825 RPM. You must not exceed the maximum allowable speed marked on your tapping attachment.

**6. Always be aware of the potential hazards of a machining operation:** Sometimes working with your machine can seem routine. You may find that you are no longer concentrating on the operation. A feeling of false security can lead to serious injury. **Always** be alert to the dangers of the machines with which you work. **Always** keep hands, parts of the body, clothing, jewelry and hair out of the areas of operation when the machine spindle is rotating. Areas of operation include the immediate point of machining and all transmission components including the tapping attachment. **Never** bring your hand, other parts of the body or anything attached to your person into any of these areas until the machine spindle is completely stopped.

**TAPMATIC**

ISO 9001 CERTIFIED: 802 CLEARWATER LOOP, POST FALLS, ID 83854

# Safety and Operation for 90x II Self Reversing Tapping Attachments

---



**Warning:** To avoid serious injury and ensure best results for your tapping operation, please read carefully *all* operator and safety instructions provided for this tapping unit as well as all other safety instructions that are applicable, especially those for your machine.

7. Be aware of any other applicable safety instructions/requirements especially those for your machine.

8. The tapping attachment housing, drive spindle and tap itself can become hot to the touch after operation. Use caution when removing the attachment from the machine or handling.

## Check List For Good Tapping

1. **Never** use this tapping attachment before reading all safety instructions for it as well as the machine it is to be used on.
2. Be sure tap is sharp and of correct design for your application.
3. Be sure tap is in proper alignment with the drilled hole.
4. Be sure the machine speed is correct.
5. Be sure you are following the correct feed rate for the tap based on the pitch of the tap and revolutions per minute.
6. Make sure the drilled hole is the correct size.
7. Be sure the machine stop is set correctly to avoid hitting the bottom of a blind hole. See Controlled Depth Tapping.
8. Be sure to allow for sufficient chip clearance especially when tapping blind holes.
9. Make sure the work piece is clamped rigidly so that it is not able to move, rotate, or lift.
10. Make sure there is enough clearance between the tap and work piece at the starting position and the retract position to be sure the tap is clear of the hole upon retraction. Remember the tapping attachment spindle extends during reversal out of the hole.
11. Make sure to mount a strong torque bar from the table of the machine, or to the non-rotating quill, to prevent the stop arm from rotating. The torque bar must be stronger than the largest tap in the tapping attachments capacity. It must also have a smooth surface so that the stop arm slides freely when feeding in and out of the hole.
12. Make sure to use the proper cutting fluid/lubricant for the application.

References for this safety information include but are not limited to: American National Standards Institute, [ANSI B11.8-1983](#), Coastal Video Communications Corporation [Machine Guarding](#) Copy right 1994, Society of Manufacturing Engineers Tool and [Manufacturing Engineers Handbook Volume 1 Machining](#) Library of Congress Catalog No 82-060312

**TAPMATIC**

ISO 9001 CERTIFIED: 802 CLEARWATER LOOP, POST FALLS, ID 83854

# Safety and Operation for 90x II Self Reversing Tapping Attachments

This tapping attachment can be used on all types of manually operated machines with rotating spindles. It can also be used in many automated applications. **IMPORTANT** Always follow all instructions from your machine manufacturer.

**Installing the Arbor into the tapping attachment:** Clean the thread or taper of both the arbor and the mount of the tapping head. Then install the arbor into the mount securely.

If it is a taper mount, twist the arbor as you push it into the tapping heads mount. Then use a mallet to give a sharp blow to the end of the arbor, to seat it into the taper mount of the tapping head.

**To remove a taper mount arbor,** give the arbor several sharp blows on the side using a mallet.



## Installing a Rubber Flex Collet into the tap chuck nut:

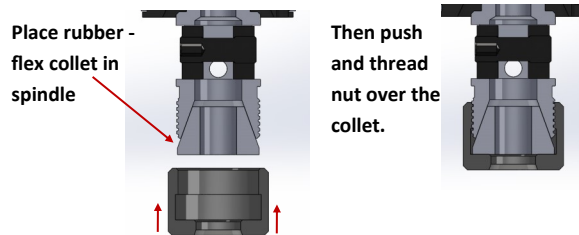

## If the tap has a male center, it should be ground off:

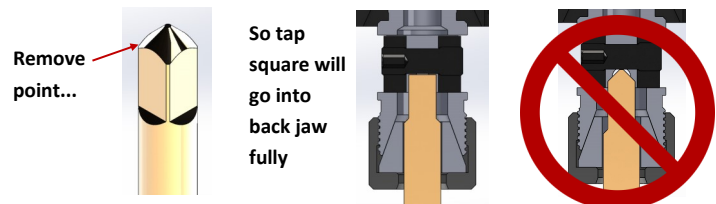

## Tightening the back jaws and the nut:

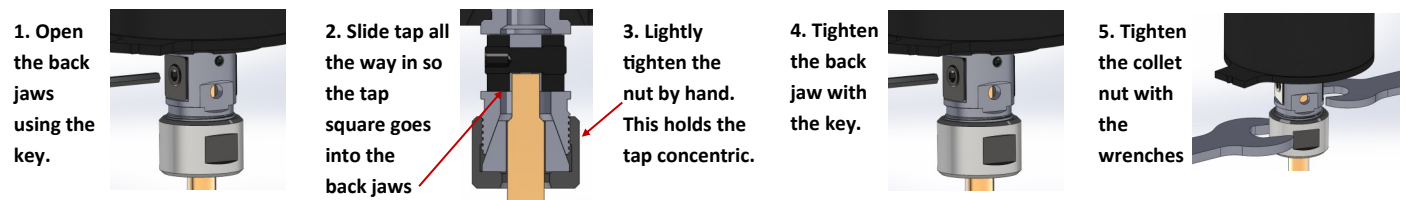

**Note:** In order to insure the tap runs concentrically, and avoid damage to back jaws or collet, it is important to follow the above steps.

## Installing the stop arm:

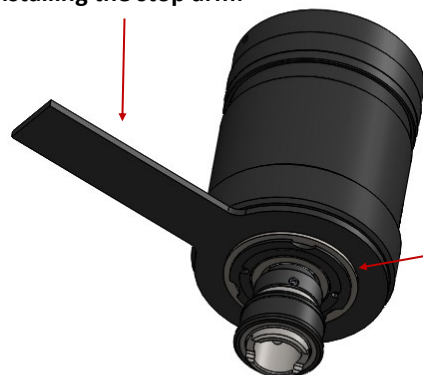

In order for the Tapping Head to reverse, the stop arm must be prevented from rotating.

See also Proper Stop Arm/Torque Bar Installation on page 1.

Use the retaining ring to mount the stop arm to the gear carrier at the bottom of the housing.

# Safety and Operation for 90x II Self Reversing Tapping Attachments

**Tapping Speeds:** The following speed recommendations are for reference only. Please consult tap manufacturer for your specific tap. **Do not exceed the maximum speed for tapping attachment shown on the housing.**

Material	Low Carbon Steel	High-Carbon Steel	Tool Steel Hard	SS 303, 304, 316	SS 410, 430, 17-4	SS 17-4 Anneal.	Titan. Alloys	Ni Alloys	Alum Alloys	Alum Die cast	Magn.	Brass, Bronze	Copper	Cast Iron
M/min (ft/min)	10-20 (33-66)	8-12 (26-39)	4-6 (13-20)	6-12 (20-39)	3-5 (10-16)	6-12 (20-39)	4-8 (13-26)	3-5 (10-16)	15-25 (49-82)	10-15 (33-49)	15-25 (49-82)	15-25 (49-82)	8-12 (26-39)	10-20 (33-66)

$$\text{RPM} = \frac{\text{M/min}}{\text{Tap Diameter in mm}} \times 318.5$$

$$\text{RPM} = \frac{\text{ft/min}}{\text{Tap Diameter inch}} \times 3.82$$

## Setting the pre-selective torque control:

The torque control helps prevent tap breakage, especially when tapping blind holes. Tightening the cap down to the higher number settings on the reference scale increases torque. To set the torque, use a new tap and begin with a



**Clutch adjustment cap**

low number (low torque) setting. Try to tap the hole. When the clutch slips, there will be no sound from the fiber disc clutch. Stop the machine and tighten the cap further. Repeat this process until you can drive a sharp tap to depth. Give the cap a half turn more and lock it using the set screw in the side of the cap. This system

saves the tap from breaking if you accidentally go too deep in a blind hole. It also warns you when your tap is becoming dull so that you can replace it before it breaks. Make note of the reference number to save time when the same job comes up again.

**Self-Feed:** Every tapping attachment has a self-feed. What is self-feed? Self feed is the additional depth that the tap will go into the hole after you feed to the stop on your machine.

**90x II Self Feed 13 to 14mm**



**Setting the stop on your machine for tapping:** Please note that the tap will continue to go deeper into the hole by the self-feed distance. The total tapping depth will be based on the depth you set with your machine stop **plus** the self-feed of the tapping attachment. For example if you would like a tapping depth of 24mm and the tapping attachment's self-feed is equal to 13 to 14mm, start by setting the machine stop to allow the tap to enter the hole just 10mm. After tapping your first hole, check the depth and make any necessary adjustments to the machine stop. **Always set the machine stop to avoid tapping too deep and hitting the bottom of the hole. The torque control is intended to only be a safety back up in case you accidentally go too deep.**

**Tapping Holes:** When tapping, it is not necessary to apply any pressure as you feed in. The tap will follow it's own pitch in and out of the hole. Just follow along with the tap, keeping up with it as it enters the hole. After you reach the machine stop, lift up on the feed handle to retract the tap. The tapping attachment will automatically reverse the taps rotation when you retract. Please note that the speed increases by 1.75 to 1 in reverse, so you will need to feed out of the hole almost twice as fast as you did feeding in. Be sure to keep up with the tap as it exits the hole. If you are feeding too slowly going in or out, the tap will stop and start and you will hear a clicking sound. This clicking sound is not the clutch slipping. If this occurs you need to feed faster to keep up with the tap. Please note that if the clutch slips because the torque is not set high enough there will not be a sound coming from the clutch.



ISO 9001 CERTIFIED: 802 CLEARWATER LOOP, POST FALLS, ID 83854

# Safety and Operation for 90x II Self Reversing Tapping Attachments

---

**Lubrication:** This unit is pre-lubricated at the factory and ready for use. After 600 hours we recommend partially disassembling, cleaning and applying new grease. We recommend using a high quality NLGI 2 type of grease. We recommend returning the Tapping Attachment to Tapmatic for maintenance and repair, but if you would like to do this at your own facility, please follow the instructions shown below referring to the drawing on the next page. Please let us know if we can be of help.

**Cutting Tool Lubrication:** For the best results and longest life for your cutting tools, be sure to use the proper cutting fluid / lubricant based on your application and the type of material the work piece is made from.

## Instructions for Disassembly

1. Remove stop ring 50920 and unscrew clutch adjustment cap 50902.
2. Hold unit in vertical position and remove adjustment thrust bearing and balls 50921R.
3. Lift off spring plate 50903.
4. Carefully invert unit over clean receptacle. Clutch springs will drop out.
5. Remove tap chuck nut 50918 and collet.
6. Remove back jaw retainer screw 50915.
7. Remove back jaw 50916.
8. Remove return spring 50930 by threading spring puller (supplied with unit) into spring hanger 50706 and pulling out to expose spring for removal with hook (also supplied with unit).
9. Remove truarc ring 50940 and stop arm 50932.
10. Remove lock nut 50910 using spanner wrench.
11. Lift out drive spindle 50914A and reversing sleeve sub assembly from housing.
12. Lift out spacers 509461 and 50938.
13. Lift out clutch sleeve 50907 and clutch assembly.
14. Remove shoulder clip 50945
15. Lift out clutch stack, cushion spring 50926 and driver 50927.
16. Remove drive pins 50928 from spindle 50914A.

For Reassembly clean and lubricate parts and reverse the order of the assembly procedure. We recommend applying Loctite 263 to threads of lock nut 50910 at assembly as indicated on drawing.

# Safety and Operation for 90x II Self Reversing Tapping Attachments

## 90x II Parts Listing

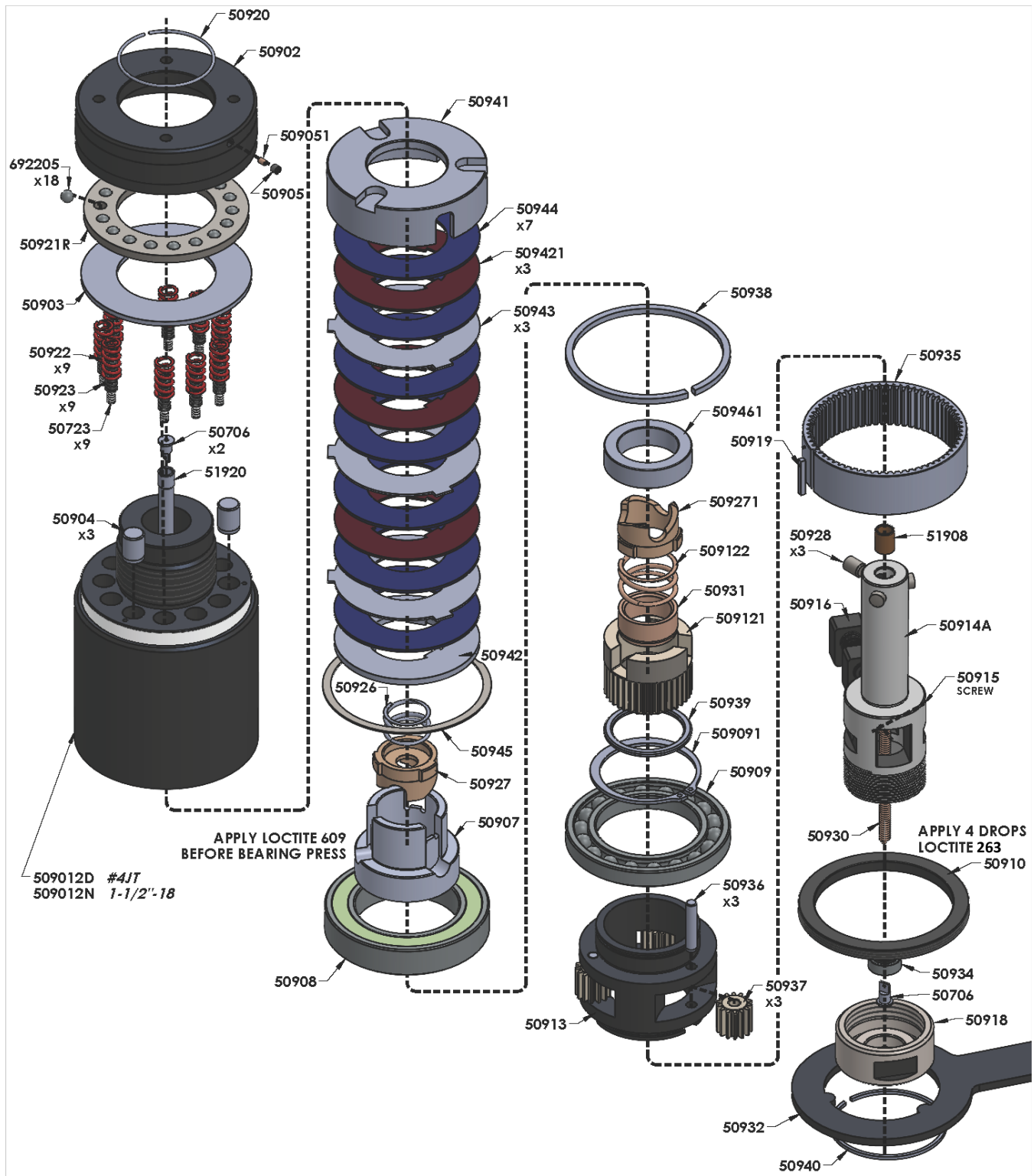

# Safety and Operation for 90x II Self Reversing Tapping Attachments

---

Repair Service is available at....

**Attention: Repair Department  
Tapmatic Corporation  
802 Clearwater Loop  
Post Falls, ID 83854**

**To Expedite Repair:** Return tool direct to Tapmatic Corporation. Tapmatic will inspect the tool and advise you of the repair costs by fax or email before the repair is completed.

**Important:** Be sure to return tool complete with collet nut, and if applicable stop arm and back jaw, because otherwise these missing parts would be added to every non-warranty repair.

**Cost Notification:** Tapmatic will FAX or E-mail a cost notification to you, soliciting your approval before repairs are completed. If it is determined that a tool cannot be repaired, at the customer's request, Tapmatic will return the disassembled parts. We are not able to reassemble a tool using damaged or worn out parts.

**Optional Return Procedure:** Tools may also be returned for repair through your local Tapmatic Distributor. They will ship the tool to us and include instructions for the repair and return. You may already have an open account with them which facilitates the handling of invoicing.

**Priority Service:** Tapmatic services tools returned for repair in the order in which they are received. All tools will be evaluated and repaired within three weeks from the date they arrive subject to receiving the customer's approval to proceed with the repair.

Priority is given to tools shipped to us by overnight or second day.

If a repair is sent to us by UPS ground or similar service, it can also be given priority. Just call and let us know you need priority service and advise if you would like the tool returned to you by overnight or second day. In the interest of fairness to all our customers, we ask that you approve shipment by overnight or second day before we agree to upgrade your repair order to priority service. Typical turn around, not including shipping time, for priority repairs is 3 days subject to receiving the customer's approval to proceed with the repair.

If we can answer any questions please call our toll free number:

**800 395-8231**

0226/90x II/

**TAPMATIC**

ISO 9001 CERTIFIED: 802 CLEARWATER LOOP, POST FALLS, ID 83854