



Safety and Operation for Drill-n-Tap 50 Self Reversing Tapping Attachments



Warning: To avoid serious injury and ensure best results for your tapping operation, please read carefully *all* operator and safety instructions provided for this tapping unit as well as all other safety instructions that are applicable, especially those for your machine.

- Proper Clothing:** The rotating spindle of a machine tool can snag loose fitting clothing, jewelry or long hair. **Never** wear jewelry, long sleeves, neckties, gloves or anything else that could become caught when operating a machine tool. Long hair **must** be restrained or netted to prevent it from becoming entangled in rotating spindle.
- Proper Eye Protection:** **Always** wear safety glasses with side shields to protect your eyes from flying particles. 
- Proper Work Piece Fixturing:** **Never** hold the work piece or the vise it is held in by hand. The workpiece **must** be clamped firmly to the table of the machine so that it cannot move, rotate or lift. 
- Proper Stop Arm/Torque Bar Installation for Self-Reversing Attachments On Conventional Machines.**



Always mount a torque bar to hold the tapping attachments stop arm from rotating. The torque bar **must** be mounted securely to the table or quill of your machine. The torque bar installation **must be stronger** than the largest tap in the capacity range of your tapping attachment. The surface of the torque bar **must be smooth** to allow the stop arm to slide freely when feeding in and out of the hole. Order Tapmatic Torque Bars shown.



Quill Clamp Capacity Ø	Order No.	Max Tap Size
1 1/2"-2 3/8" 38-60 mm	29099	1/2" or M12
2 3/8"-4 1/2" 60-114 mm	290991	3/4" or M20



Torque Bar Assembly	Order No.	Max Tap Size
Table Mount	29097	3/4" or M20
Heavy Duty Table Mount	29096	1 3/4" or M42

Never extend the length of the standard stop arm supplied with your tapping attachment. A lengthened stop arm could break free hitting the operator and causing serious injury.

Never hold the stop arm by hand. On reversal, full power of the machine is transmitted through the stop arm and the operator could be seriously injured.



5. Do not exceed the maximum speed for the tapping head: Speed is a critical factor in tapping. Please always refer to recommended tapping speed chart. Tapmatic torque control reversing tapping attachments employ a planetary gear for increased speed in reverse. The revolutions per minute when reversing out of the hole will be 1.75 times faster than the machine spindle speed. It is strongly recommended that you consider the **Average Tapping Speed** rather than machine speed when calculating cycle time. For example if machine speed is 1500 RPM, reverse speed is 2625 RPM making your Average Tapping Speed 2062 RPM. You must not exceed the maximum allowable speed marked on your tapping attachment.

6. Always be aware of the potential hazards of a machining operation: Sometimes working with your machine can seem routine. You may find that you are no longer concentrating on the operation. A feeling of false security can lead to serious injury. **Always** be alert to the dangers of the machines with which you work. **Always** keep hands, parts of the body, clothing, jewelry and hair out of the areas of operation when the machine spindle is rotating. Areas of operation include the immediate point of machining and all transmission components including the tapping attachment. **Never** bring your hand, other parts of the body or anything attached to your person into any of these areas until the machine spindle is completely stopped.

TAPMATIC

ISO 9001 CERTIFIED: 802 CLEARWATER LOOP, POST FALLS, ID 83854

Safety and Operation for Drill-n-Tap 50 Self Reversing Tapping Attachments



Warning: To avoid serious injury and ensure best results for your tapping operation, please read carefully *all* operator and safety instructions provided for this tapping unit as well as all other safety instructions that are applicable, especially those for your machine.

7. Be aware of any other applicable safety instructions/requirements especially those for your machine.
8. The tapping attachment housing, drive spindle and tap itself can become hot to the touch after operation. Use caution when removing the attachment from the machine or handling.

Check List For Good Tapping

1. **Never** use this tapping attachment before reading all safety instructions for it as well as the machine it is to be used on.
2. Be sure tap is sharp and of correct design for your application.
3. Be sure tap is in proper alignment with the drilled hole.
4. Be sure the machine speed is correct.
5. Be sure you are following the correct feed rate for the tap based on the pitch of the tap and revolutions per minute.
6. Make sure the drilled hole is the correct size.
7. Be sure the machine stop is set correctly to avoid hitting the bottom of a blind hole. See Controlled Depth Tapping.
8. Be sure to allow for sufficient chip clearance especially when tapping blind holes.
9. Make sure the work piece is clamped rigidly so that it is not able to move, rotate, or lift.
10. Make sure there is enough clearance between the tap and work piece at the starting position and the retract position to be sure the tap is clear of the hole upon retraction. Remember the tapping attachment spindle extends during reversal out of the hole.
11. Make sure to mount a strong torque bar from the table of the machine, or to the non-rotating quill, to prevent the stop arm from rotating. The torque bar must be stronger than the largest tap in the tapping attachments capacity. It must also have a smooth surface so that the stop arm slides freely when feeding in and out of the hole.
12. Make sure to use the proper cutting fluid/lubricant for the application.
13. If using the Drill-n-Tap for drilling, be sure to set hard start collar correctly, see Setting the Hard Start/Self Feed Adjustment. Make sure the drill is sharp and use the proper speed being sure not to exceed the maximum revolutions per minute for the tapping attachment.

References for this safety information include but are not limited to: American National Standards Institute, [ANSI B11.8-1983](#), Coastal Video Communications Corporation [Machine Guarding](#) Copy right 1994, Society of Manufacturing Engineers Tool and [Manufacturing Engineers Handbook Volume 1 Machining](#) Library of Congress Catalog No 82-060312

TAPMATIC

ISO 9001 CERTIFIED: 802 CLEARWATER LOOP, POST FALLS, ID 83854

Safety and Operation for Drill-n-Tap 50 Self Reversing Tapping Attachments

This tapping attachment can be used on all types of manually operated machines with rotating spindles. It can also be used in many automated applications. **IMPORTANT** Always follow all instructions from your machine manufacturer.

Installing the Arbor into the tapping attachment: Clean the thread or taper of both the arbor and the mount of the tapping head. Then install the arbor into the mount securely.

If it is a taper mount, twist the arbor as you push it into the tapping head's mount. Then use a mallet to give a sharp blow to the end of the arbor, to seat it into the taper mount of the tapping head.

To remove a taper mount arbor, give the arbor several sharp blows on the side using a mallet.



Installing an adapter into the quick change spindle:

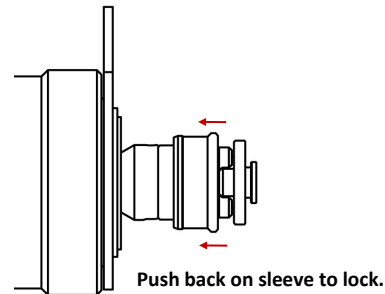
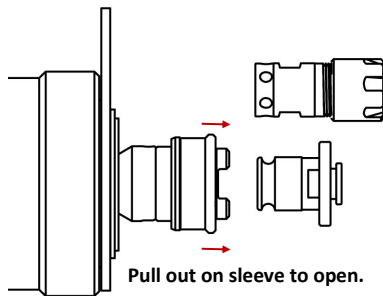

Installing a tap into a positive drive tap adapter:

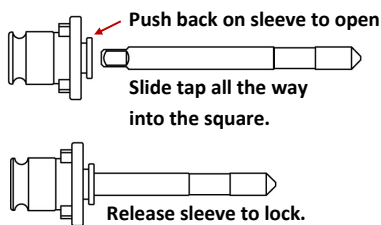

Installing an ER collet into the ER collet adapter:

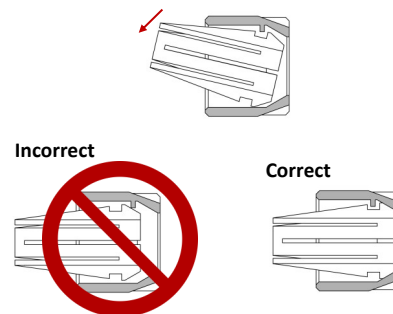

Always install the collet into the nut first. Make sure lip inside the nut goes into the collets groove. Use square drive collets for taps and standard collets for drills.

Installing the stop arm:

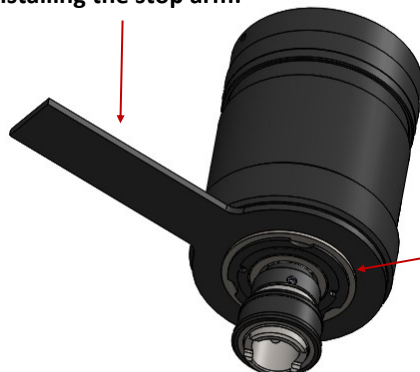

See also Proper Stop Arm/Torque Bar Installation on page 1.

Use the Spirolox retaining ring to mount the stop arm to the gear carrier at the bottom of the housing.



ISO 9001 CERTIFIED: 802 CLEARWATER LOOP, POST FALLS, ID 83854

PHONE: (800) 854-6019 OR (208) 773-2951, FAX: (208) 773-3021, E-MAIL: info@tapmatic.com, WEB: www.tapmatic.com

Safety and Operation for Drill-n-Tap 50 Self Reversing Tapping Attachments

Tapping Speeds: The following speed recommendations are for reference only. Please consult tap manufacturer for your specific tap. **Do not exceed the maximum speed for tapping attachment shown on the housing.**

Material	Low Carbon Steel	High-Carbon Steel	Tool Steel Hard	SS 303, 304, 316	SS 410, 430, 17-4 Hard	SS 17-4 Anneal.	Titan. Alloys	Ni Alloys	Alum Alloys	Alum Die cast	Magn.	Brass, Bronze	Copper	Cast Iron
M/min (ft/min)	10-20 (33-66)	8-12 (26-39)	4-6 (13-20)	6-12 (20-39)	3-5 (10-16)	6-12 (20-39)	4-8 (13-26)	3-5 (10-16)	15-25 (49-82)	10-15 (33-49)	15-25 (49-82)	15-25 (49-82)	8-12 (26-39)	10-20 (33-66)

$$\text{RPM} = \frac{\text{M/min}}{\text{Tap Diameter in mm}} \times 318.5$$

$$\text{RPM} = \frac{\text{ft/min}}{\text{Tap Diameter inch}} \times 3.82$$

Setting the Hard start/Depth control collar: Below are figures showing the different settings that can be used.

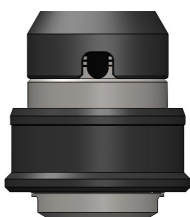

Cushion Setting: For normal tapping it can be helpful to have compression or cushion when starting the tap into the hole. This is also needed for re-entering a previously tapped hole.
Self Feed for tapping in this position: Size 50, 4 to 5mm.



Hard Start: Use this position for drilling. Push up against the QC spindle and it should not compress. May also be used for tapping. Hard start can help make the tapping depth more consistent. **Self Feed for tapping in this position: Size 50, 3 to 4mm.**



Self Feed Reduced approx. 1mm: When tapping shallow depth holes, it can be helpful to reduce the self-feed of the tapping attachment. **Self Feed for tapping in this position: Size 50, 2 to 3mm.**

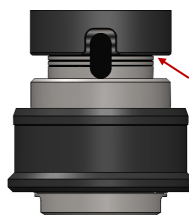

Do not go past this line for size 50.

Self Feed Reduced approx. 2mm (Size 50 only) Important! This is the maximum distance the collar should be raised. Going further can eliminate the attachments forward drive.
Self Feed for tapping in this position is 1 to 2mm.

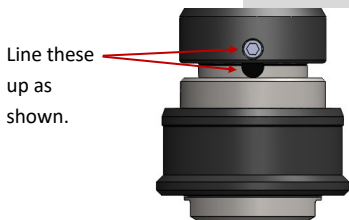

Line these up as shown.

Locking the collar setting: Firmly tighten the set screw to lock the position of the collar. Make sure to line up the set screw with one of the two milled channels (they are 180° apart)

What is self-feed? Self feed is the additional depth that the tap will go into the hole after you feed to the stop on your machine.

Setting the pre-selective torque control:

The torque control helps prevent tap breakage, especially when tapping blind holes. Tightening the cap down to the higher number settings on the reference scale increases torque. To set the torque, use a new tap and begin with a low number (low torque) setting. Try to tap the hole. The clutch will slip and you will hear a loud ratcheting sound. Stop the machine and tighten the cap further. Repeat this process until you can drive a sharp tap to depth. Give the cap a half turn more and lock it using the set screw in the side of the cap. This system saves the tap from breaking if you accidentally go too deep in a blind hole. It also warns you when your tap is becoming dull so that you can replace it before it breaks. Make note of the reference number to save time when the same job comes up again.



Clutch adjustment cap



Reference Numbers

Safety and Operation for Drill-n-Tap 50 Self Reversing Tapping Attachments

Setting the stop on your machine for tapping: Please note that the tap will continue to go deeper into the hole by the self-feed distance. The total tapping depth will be based on the depth you set with your machine stop **plus** the self-feed of the tapping attachment. For example if you would like a tapping depth of 10mm and the tapping attachment's hard start/depth control collar is set to the hard start position with self-feed equal to 3 to 4mm, start by setting the machine stop to allow the tap to enter the hole just 6mm. After tapping your first hole, check the depth and make any necessary adjustments to the machine stop. **Always set the machine stop to avoid tapping too deep and hitting the bottom of the hole. The torque control is intended to only be a safety back up in case you accidentally go too deep.**



Setting the stop on your machine for drilling: Be sure you have the hard start/depth control collar in the hard start setting. Then set your machine stop according to the drilling depth desired. With drilling it is not necessary to allow for self-feed.

Please refer to previous page for information about self-feed and setting the hard start/depth control collar.

Tapping Holes: When tapping, it is not necessary to apply any pressure as you feed in. The tap will follow it's own pitch in and out of the hole. Just follow along with the tap, keeping up with it as it enters the hole. After you reach the machine stop, lift up on the feed handle to retract the tap. The tapping attachment will automatically reverse the taps rotation when you retract. Please note that the speed increases by 1.75 to 1 in reverse, so you will need to feed out of the hole almost twice as fast as you did feeding in. Be sure to keep up with the tap as it exits the hole. If you are feeding too slowly going in or out, the tap will stop and start and you will hear a clicking sound. If this occurs you need to feed faster to keep up with the tap. Please note that if the clutch slips because the torque is not set high enough you will hear a much louder ratchetting sound.

Drilling Holes: Be sure the hard start/depth control collar is in the hard start position (see previous page). Maintain a steady pressure as you feed into the work piece. If drilling through the material, slowing down the feed just before breaking through will help to reduce burrs, and a sharp drill will also produce less of a burr when breaking through. When the drill breaks through, there will be a tendency for the burr to pull slightly on the drill at first. When you retract from the hole the spindle of the tapping attachment should return to the fully retracted hard start position.

Lubrication: This unit is pre-lubricated at the factory and ready for use. After 600 hours we recommend partially disassembling the Drill-n-Tap, cleaning and applying new grease. We recommend using a high quality NLGI 2 type of grease. We recommend returning the Drill-n-Tap to Tapmatic for maintenance and repair, but if you would like to do this at your own facility, please follow the instructions shown on the next page. Please let us know if we can be of help.

Cutting Tool Lubrication: For the best results and longest life for your cutting tools, be sure to use the proper cutting fluid / lubricant based on your application and the type of material the work piece is made from.

Parts Listing Drill-n-Tap 50 Self Reversing Tapping Attachments

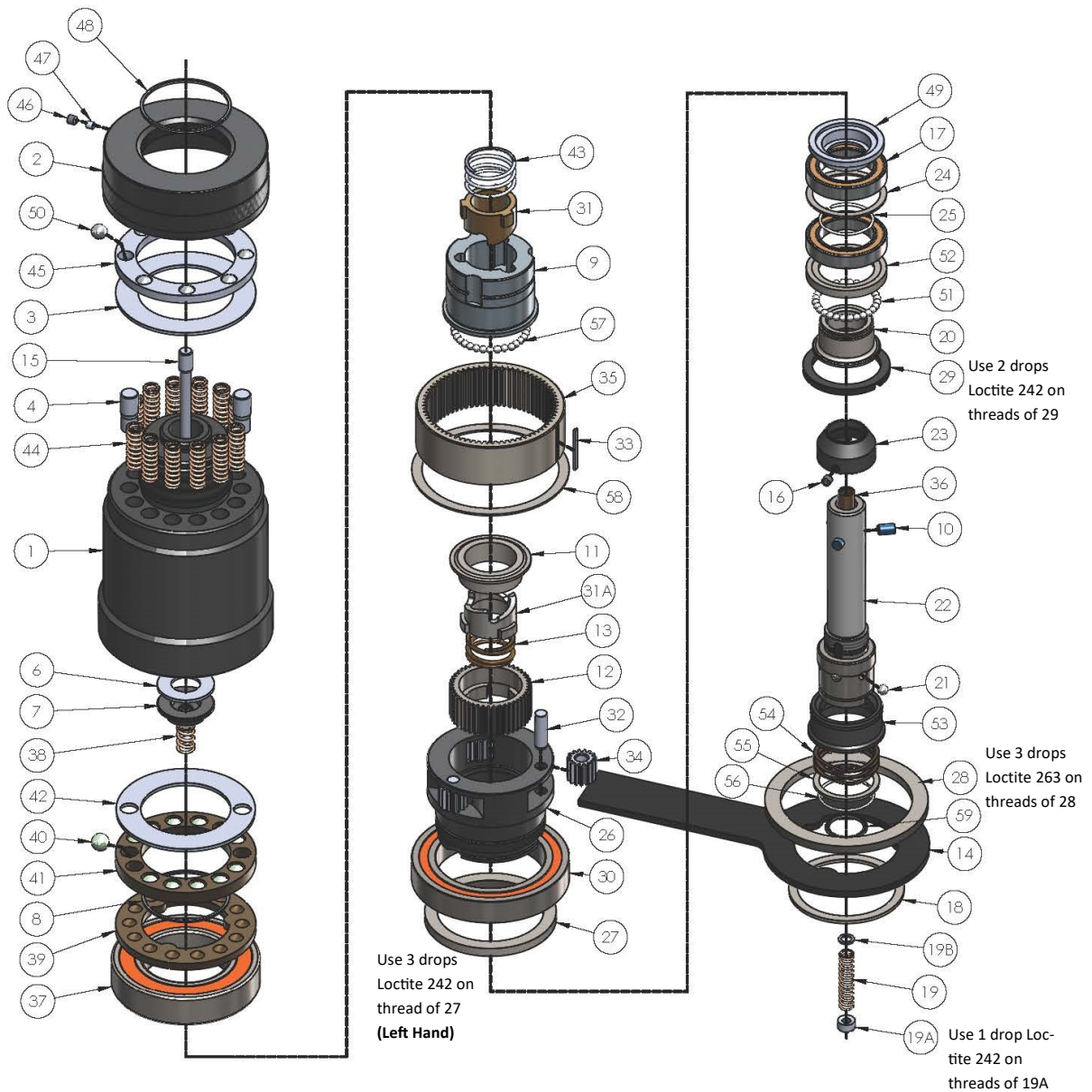

INSTRUCTIONS FOR DISASSEMBLY

1. For partial disassembly, screw clutch adjustment cap (2) fully upward to relieve clutch spring pressure. For total disassembly, remove top ring(48), unscrew and remove clutch adjustment cap (2).
2. Remove thrust bearing (45), spring cap (3), and clutch springs (44).
3. Use slotted screw driver to remove guide spindle nut (19A).
4. Remove retaining ring (18), stop arm (14), and lock nut (28).
5. With tapping head mount down and QC spindle up, grasp three lobes of gear carrier (26) and lift out complete sub assembly. Use friction washer sleeve (11) to keep balls (57) in place.
6. Remove ring gear (35) and key (33).
7. Hold friction washer sleeve (11) in place to prevent balls (57) from falling out, invert housing over a clean receptacle, and slide the clutch assembly (9) and bearing (37) out of the housing being careful not to lose clutch balls (40).
8. Replace worn parts, clean and apply approximately 4cc of a high quality NLGI 2 type of grease to gears.

INSTRUCTIONS FOR ASSEMBLY

1. Reverse procedure for disassembly and please note the use of Loctite where indicated on the drawing.

TAPMATIC

ISO 9001 CERTIFIED: 802 CLEARWATER LOOP, POST FALLS, ID 83854

Parts Listing Drill-n-Tap 50 Self Reversing Tapping Attachments

IDENT.	PART NAME	PART NO. Size 50
1	HOUSING #6JT	64501GBB
1	HOUSING #33JT	64501GBE
1	HOUSING DINB16	64501GBG
1	HOUSING 1/2-20	64501GBJ
1	HOUSING 5/8-16	64501GBK
2	CLUTCH ADJUSTMENT CAP	60502
3	SPRING PLATE	60503
4	CLUTCH PIN	60505B (2)
6	HOUSING FRICTION WASHER	64528
7	SPINDLE STOP	64529
8	RETAINING RING	60529B
9	CLUTCH SLEEVE	64507G
10	DRIVE PIN	56528 (3)
11	ANTI-FRICTION SLEEVE	64515
12	REVERSING SLEEVE	64512G
13	REVERSING DRIVE SPRING	58512
14	STOP ARM	64532G
15	GUIDE SPINDLE	64523
16	M4 SET SCREW	64505
17	BEARING	70805 (2)
18	RETAINING RING	64542
19	RETURN SPRING	58528
19A	GUIDE SPINDLE NUT	56534
19B	RETURN SPRING CUP/WASHER	70928
20	DRIVE SPINDLE BUSHING	64531
21	QUICK CHANGE BALL	69575 (6)
22	DRIVE SPINDLE	64570
23	HARD START/DEPTH CONTROL COLLAR	64536
24	WASHER	64541
25	RETAINING RING	50320
26	GEAR CARRIER	64513G
27	LOCK NUT (LEFT HAND THREAD)	64547
28	HOUSING LOCK NUT	645132G
29	LOCK NUT	64548
30	GEAR CARRIER BEARING	71309O
31	FORWARD DRIVER	505272
31A	REVERSE DRIVER	58504
32	GEAR PINS	64536G (3)
33	KEY	50719
34	PLANET GEARS	60537 (3)
35	RING GEAR	60535BG
36	GUIDE SPINDLE BUSHING	56529
37	BALL BEARING	50708O
38	CUSHION SPRING	58536
39	CLUTCH DRIVER	60541
40	CLUTCH BALLS	60728 (12)
41	BALL CLUTCH PLATE	60543
42	FRICTION WASHER	60544B
43	DRIVE SPRING	51512
44	CLUTCH SPRING	607221 (12)
45	ADJUSTMENT THRUST PLATE	64521
46	LOCK SET SCREW	50305
47	LOCK SET SCREW PLUG	503051
48	STOP RING	60529
49	REVERSE SPRING HOLDER	64557G
50	ADJ. BEARING BALLS	692205 (8)
51	THRUST BEARING BALLS	82039 (28)
52	THRUST SPACER	64549
53	QC SLEEVE	82071
54	QC SPRING	82077
55	QC WASHER	82069
56	RETAINING RING	69573
57	THRUST BEARING BALLS	82039 (32)
58	SPACER	64543
59	SPINDLE BORE O-RING	81083

NOTE:

- Housing (1) only available as an assembly with (4) and (15).
- Clutch Cap (2) includes (46) and (47).
- Drive spindle (22) includes (36).

WRENCHES

KEY 2MM 27222

(ONLY THREAD MOUNTS)
 SPANNER 60360 (SIZE 30)
 SPANNER 29070 (SIZE 50)



ISO 9001 CERTIFIED: 802 CLEARWATER LOOP, POST FALLS, ID 83854

Drill-n-Tap 50 Self Reversing Tapping Attachments

Repair Service is available at....

**Attention: Repair Department
Tapmatic Corporation
802 Clearwater Loop
Post Falls, ID 83854**

To Expedite Repair: Return tool direct to Tapmatic Corporation. Tapmatic will inspect the tool and advise you of the repair costs by fax or email before the repair is completed.

Important: Be sure to return tool complete with collet nut, and if applicable stop arm and back jaw, because otherwise these missing parts would be added to every non-warranty repair.

Cost Notification: Tapmatic will FAX or E-mail a cost notification to you, soliciting your approval before repairs are completed. If it is determined that a tool cannot be repaired, at the customer's request, Tapmatic will return the disassembled parts. We are not able to reassemble a tool using damaged or worn out parts.

Optional Return Procedure: Tools may also be returned for repair through your local Tapmatic Distributor. They will ship the tool to us and include instructions for the repair and return. You may already have an open account with them which facilitates the handling of invoicing.

Priority Service: Tapmatic services tools returned for repair in the order in which they are received. All tools will be evaluated and repaired within three weeks from the date they arrive subject to receiving the customer's approval to proceed with the repair.

Priority is given to tools shipped to us by overnight or second day.

If a repair is sent to us by UPS ground or similar service, it can also be given priority. Just call and let us know you need priority service and advise if you would like the tool returned to you by overnight or second day. In the interest of fairness to all our customers, we ask that you approve shipment by overnight or second day before we agree to upgrade your repair order to priority service. Typical turn around, not including shipping time, for priority repairs is 3 days subject to receiving the customer's approval to proceed with the repair.

If we can answer any questions please call our toll free number:

800 395-8231

Drill-n-Tap 50 021926

TAPMATIC

ISO 9001 CERTIFIED: 802 CLEARWATER LOOP, POST FALLS, ID 83854