

Large capacity self-reversing tapping attachment for high production with pre-selective torque control

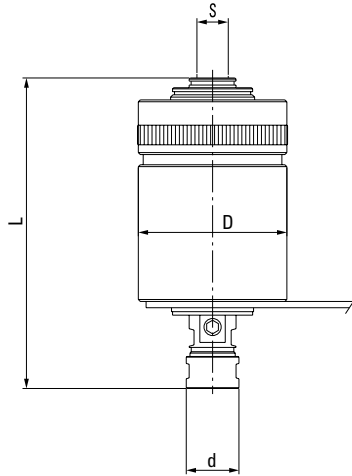

- less tap breakage due to pre-selective torque control
- easy adaptation with multiple interchangeable arbors
- reduced cycle time through increased 1.75:1 reverse speed
- only 2 Rubber Flex collets per model required.

How to Order

Please select the tapping attachment (A) and arbor (C) to fit your application. Choose an arbor to fit the thread or taper mount of the tapping attachment, with the Morse Taper, R8 or straight shank to fit your machine. Please order rubber flex collets and torque bars separately .

Dimensions

Model	D	d	Self-feed	Weight kg
90X	105	57	13	5.0

(A) Model	Capacity (steel)	Collets Rubber Flex Order Code (Shank Ø)	Mount S (Internal Taper or Thread)	Order code	L	Max. RPM
90X	M10-M30	26100 (10.0-16.0)	#4 Jacobs Taper	10904	219	600
	1/2" - 1 1/8"	26200 (16.0-23.0)	1 1/2"-18 Thread	10915		

Note: When using Roll Form Taps the tool's tapping capacity must be reduced by 25%.

* All dimensions are shown in mm. 25.4mm = 1"

RF Rubber Flex Collets

Tapping Head Capacity	RF Collet Order code	Clamping Capacity (mm)	Tap Capacity Metric Sizes (DIN 371, 374)	Tap Capacity Inch Sizes
M10-M30	26100	10.0-16.0	M10, M14-M20	9/16"-3/4"
1/2"-1 1/8"	26200	16.0-23.0	M20-M30	13/16"-1 1/8"

